

Jain Dualism -1: A Philosophical and Scientific Analysis

–Dr. N.L. Kachhara

Introduction

Understanding the existence of self is the central issue in all religions. Philosophy also aims for search of knowledge especially concerning nature and the meaning of existence. Psychology explores the human behaviour and science provides the facts of the physical world. An integration of these disciplines can greatly enhance our understanding and properly guide our conduct and behaviour. The thing, which distinguishes us from innate matter, is consciousness. Explaining the nature of consciousness is one of the important and perplexing areas of modern philosophy and science. The concepts of Jain philosophy offer solutions to many of the problems facing philosophers and scientists.

Etymologically, consciousness implies one's ability to know and perceive. Through consciousness, one can have knowledge of the external world or one's own mental state. Perhaps the most commonly used contemporary notion of conscious mental state is captured by Thomas Nagel's famous "what it is like" sense. But how do we understand this? One use of "conscious" is applied to a person's total state. According to the accepted notion in philosophy a person is conscious, in the sense, if he or she is in a generalized condition of alertness or arousal: being awake rather than asleep or in a coma. "Awareness" is just an approximate synonym of "conscious", and so is "phenomenal". Attempts at definition might try to define consciousness (semi) operationally, by reference to the sort of behaviour that would provide public or external evidence for consciousness.

There are two broad traditional and competing metaphysical views concerning the nature of mind and conscious mental states: dualism and materialism. While there are many versions of each, the former generally holds that the conscious mind or a conscious mental state is non-physical in some sense. On the other hand, materialists hold that the mind is the brain, or more accurately, that conscious mental activity is identical to neural

activity. It is important to recognize that by non-physical dualists mean something literally outside the realm of physics; that is, not in space at all and undetectable in principle by instruments of physics. Dualists, then, tend to believe that conscious mental states or minds are radically different from anything in the physical world.

Dualism

The most basic form of dualism is substance dualism, which requires that mind and body be composed of two ontologically different substances: the mind is comprised of a non-physical substance, while body is constructed of the physical substance known as matter. The mind is a thinking thing that lacks the usual attributes of physical objects: size, shape, location, solidity, motion, adherence to the law of physics, and so on.

Historically, there is a clear link between dualism and a belief in immortality, and hence a more theistic perspective than one can be found among materialists. If the conscious mind is not physical, it seems more plausible to believe in the possibility of life after bodily death. On the other hand, if conscious mental activity is identical with brain activity, then it would seem that when all brain activity ceases, so do all conscious experiences and thus no immortality. If we are entirely physical beings as the materialist holds, then must not all of the brain activity and behaviour in question be determined by the laws of nature?

One might wonder "even if the mind is physical, what about the soul"? May be it is the soul, not the mind, which is non-physical. While it is true that the term "soul" (or "spirit") is often used instead of mind, the problem in philosophy is that it is unclear just how the soul is supposed to differ from mind. The terms are often even used interchangeably by many philosophers because it is unclear to them what else the soul could be other than "the mental substance". Somewhat related to the issue of immortality, the existence of near-death experiences is also used as some evidence for dualism and immortality. Various paranormal and psychic phenomena, such as clairvoyance, faith healing, and mind reading, are sometimes also cited as evidences for dualism.

According to most substance dualists, mind and body are capable of causally affecting each other. This form of substance dualism is known as interactionism. Two other forms of dualism are occasionalism and parallelism. The occasionalism holds that mind and body don't interact. According to parallelism, our mental and physical histories are coordinated so that mental events appear to cause physical events (and vice versa) by virtue of their temporal conjunction, but mind and body no more interact than two clocks are synchronized so that one chimes when hands of the other point out the new hour. Another form of dualism is Property Dualism, which claims that mental phenomena are non-physical properties of physical phenomena, but not properties of non-physical substance.

Many philosophers support dualism. Nyaya and Sankhya systems of Indian philosophy support dualism. Plato likens the body to a prison in which the soul is confined. Plato and Socrates provide several arguments in support of the contention that soul can exist without the body. Descartes calls the mind a thinking thing that thinks and not an extended thing. He defines body as an extended thing and not a thing that thinks. Descartes states, "I am present to my body not merely in a way a seaman is present to his ship but....I am tightly joined and, so to speak, mingled together with it, so much so that I make up one single thing with it." Descartes also advanced several arguments to justify the distinction of mind and body. Dualists have also argued for their position by employing Leibniz's Law in many ingenious ways. Such arguments are typically thought to share a common flaw: they assume that because some aspect of mental states, such as privacy, intentionality, truth, or meaning cannot be attributed to physical substances, they must be attributable to non-physical substances. Another argument for dualism claims that dualism is required for free will.

There are, however, some objections to dualism. Paul Churchland has argued that dualism is inconsistent with the facts of human evolution and fetal development. According to this view, we began as wholly physical beings. No one seriously supposes that newly fertilized ova are imbued with minds or that the original cell in the primordial

sea was conscious. But from that entirely physical organ, nothing non-physical was later added. Others argue that dualism is scientifically unacceptable because it violates the well-established principle of conservation of energy. Inter-actionists argue that mind and matter causally interact. But the spiritual realm is continually impinging on the universe and affecting changes; the total level of energy in the cosmos must be increasing or at least fluctuating.

Since the mind is immaterial and unexpanded, how can it act on bodies? Epiphenomenalism is a dualistic theory of mind designed, in part, to avoid the difficulties involved in mental-physical causation. According to epiphenomenalism, bodies are able to act on minds, but not the reverse. The causes of behaviour are wholly physical. Unfortunately epiphenomenalism avoids the problem of interaction only at the expense of denying the common sense view that our states of mind have some bearings on our conduct. Epiphenomenalism is therefore not a viable theory of mind.

The correlation and dependence argument against dualism begins by noting that there are clear correlations between certain mental events and neural events (say, between pain and a-fiber or c-fiber stimulation). Also, as demonstrated in such phenomena as memory loss due to head trauma or wasting disease, the mind and its capacities seem dependent upon neural function. Descartes defends dualism by illustrating the following example : a virtuous violinist cannot manifest his or her ability if given an instrument in deplorable or broken condition. So, if the brain is in a severely diseased or injurious state, the mind cannot demonstrate its abilities; they of necessity remain private and unrevealed.

Some philosophers, such as Hume, have objected that supposing that the mind is a thinking thing is not warranted since all we apprehend of the self by introspection is a collection of ideas but never the mind that purportedly has these ideas. All we are therefore left with is a stream of impressions and ideas but no persisting, substantial self to constitute personal identity. Kant, too, denied that the mind is a substance. Mind is simply the unifying factor that is the logical preliminary to experience.

Materialism

Some form of materialism is probably much more widely held today than in centuries past. No doubt part of the reason for this has to do with the explosion in scientific knowledge about the working of the brain and its intimate connection with consciousness, including the close connection between brain damage and various states of consciousness. Indeed, materialism often seems to be a working assumption in neurophysiology. The idea the science is showing us is that the conscious mental states, such as visual perceptions, are simply identical with certain neuro-chemical brain processes.

There are, however, a number of much discussed and important objections to materialism most of which question the notion that materialism can adequately explain conscious experience. Joseph Levine coined the expression "the explanatory gap" to express the difficulty for any materialistic attempt to explain consciousness. David Chalmers similarly points to "the hard problem of consciousness", which basically refers to the difficulty of explaining just how physical processes in the brain give rise to subjective conscious experiences, or experience an emotion. Chalmers usefully distinguishes the hard problem of consciousness from what he calls the "easy problem" of consciousness, such as ability to discriminate and categorize stimuli, the ability of a cognitive system to access its own internal state, and the difference between wakefulness and sleep. The easy problems generally have more to do with the functions of consciousness solving them doesn't touch the hard problem of phenomenal consciousness.

Another objection to materialism is the knowledge argument, forwarded by Thomas Nagel and Frank Jackson. The general pattern of each argument is to assume that all the physical facts are known about some conscious mind or experience. Yet not all is known about the mind or experience. It is then inferred that the missing knowledge is non-physical in some sense, which is surely an anti-materialist conclusion in some way.

Despite the plethora of materialist responses, vigorous debate continues as there are those who still think that something profound must always be missing from any materialist attempt to explain consciousness; namely, that understanding subjective phenomenal consciousness is an inherently first-person activity which cannot be captured by any objective third-person scientific means, no matter how much scientific knowledge is accumulated. Some knowledge about consciousness is essentially limited to first-person knowledge. Perhaps consciousness is simply a fundamental or irreducible part of nature in some sense.

Religious beliefs have always held that there is an intelligent cause for origin of life. The design argument assumes that the order we see in the world around us bears an analogy to the kind of order exhibited by human artifacts. Since the two kinds of order are similar, the cause of one must be similar to the cause of the other. The order in human artifacts is the result of human intelligence. Therefore, the order in the world must be the result of an intelligent being. DNA is considered the identifying mark of a living system. In recent years, scientists have applied information theory to biology, and in particular to the genetic code. The amount of information in the DNA of even the single – celled bacterium, E. Coli, is vast indeed. It is greater than the information contained in the books in any of world's largest libraries. A DNA code is a very special kind of order. The sequence of nucleotides in DNA or amino acids in a protein is like the letters in a written language. There is no detectable difference between the sequence of nucleotides in E. Coli DNA and a random sequence of nucleotides. Yet within the E. Coli cells, the sequence of "letters" of its DNA is very specific. Only that particular sequence is capable of biological function.

The discovery that life in its essence is information inscribed on DNA has greatly narrowed the question of life's origin. With the insights from information theory we need no longer argue from order in a general sense. Order with low information content does arise by natural processes. However, there is no convincing experimental evidence that order with high information content can arise by natural process. Indeed, the only

evidence we have is that it takes intelligence to produce the second kind of order. If we want to speculate on how the first informational molecules came into being, the most reasonable speculation is there was some form of intelligence around at that time. Even the simplest form of life, with their store of DNA, is characterized by specified complexity. Therefore life itself is prima facie evidence that some form of intelligence was in existence at the origin of DNA code. The claim that DNA arose by material forces is to say that information can arise by material forces. However, the material base of a message is completely independent of the information transmitted. The material base couldn't have anything to do with the message's origin. The information within the genetic code is entirely independent of the chemical makeup of the DNA molecule. To accept a material cause for the origin of life actually runs counter to the principle of uniformity.

Scientists still hold the view that physical information exists regardless of the presence of intelligence, and evolution allows for new information whenever a novel mutation or gene duplication occurs and is kept. It doesn't need to be beneficial nor visually apparent to be "information". However, even if those were requirements they could be satisfied with the appearance of nylon-eating bacteria, which required new enzymes to digest a material that never existed until the modern age.

Some philosophers argue that we are simply not capable of solving the problem of consciousness. The "mysterians" believe that the hard problem can never be solved because of human cognitive limitations; the explanatory gap can never be filled. Some argue that we are "cognitively closed" with respect to this problem much like a rat or dog is cognitively incapable of solving, or even understanding, calculus problems. McGinn claims that we are cognitively closed as to how brain produces conscious awareness. He concedes that some brain property produces conscious experience, but we cannot understand how this is so or even know what that brain property is. Our concept forming mechanism simply will not allow us to grasp the physical and causal basis of consciousness. We are not conceptually suited to be able to do so. McGinn observes that

we don't have a mental faculty that can access both consciousness and the brain. We access consciousness through introspection or the first-person perspective, but our access to the brain is through the use of outer spatial senses (e.g., vision) or more third-person perspective. Thus we have no way to access both the brain and consciousness together, and therefore any explanatory link between them is forever beyond our reach.

Unconscious Mind

Freud divided mind into three parts, Id, Ego, and Super Ego. The Id comprises the unorganized part of the personality structure that contains the basic drives. The Id is unconscious by definition; it is the storehouse of instinctual desires, needs, and psychic actions. While past thoughts and memories may be deleted from immediate consciousness, they direct the thoughts and feelings of the individual from the realm of the unconscious. The Ego comprises the organized part of the personality structure, which includes defensive, perceptual, intellectual-cognitive, and executive functions. Conscious awareness resides in the Ego, although not all of the operations of the ego are conscious. Consciousness, in Freud's topographical views was a relatively thin perceptual aspect of mind, whereas the subconscious was that merely autonomic function of the brain. The Super-Ego comprises that organized part of the personality structure, mainly but not entirely unconscious, that includes the individual ego ideals, spiritual goals, and psychic agency (commonly called 'conscience') that criticizes and prohibits his or her drives, fantasies, feelings and actions. Although the id is unconscious by definition, the ego and super ego are both partly conscious and partly unconscious. Unconscious thoughts are not directly accessible to ordinary introspection, but are supposed to be capable of being "tapped" and "interpreted" by special methods and techniques such as random association, dream analysis and verbal slips examined and conducted during psychoanalysis.

Today, there are still fundamental disagreements within psychology about the nature of the unconscious mind. There is a great controversy over the concept of an unconscious in regard to its scientific or rational validity and whether the unconscious

mind exists at all. Given the lack of evidence of many Freudian hypotheses, some scientific researchers proposed the existence of unconscious mechanisms that are very different from Freudian ones. In modern cognitive psychology, which is more materialistic, many researchers have sought to strip the notion of the unconscious from its Freudian heritage, and alternative terms such as 'implicit' or 'automatic' have come into currency. Cognitive research has revealed that automatically, and clearly outside of conscious awareness, individuals register and acquire more information than what they can experience through their conscious thoughts.

Jaina Dualism

The dualism in Jain philosophy is of a special kind. Besides a non-physical soul and material body there is a third unit of a subtle body comprising past memory and the mental states. The subtle body is physical but is made of fine matter known as *vargana*, which are invisible and massless. The subtle body consists of two parts, one containing long-term memory records (unconscious), up to thousands of years, known as karma body, and the other called fiery (*tejas*) body contains records of thoughts, emotions, beliefs and short-term memory (conscious). Another important function performed by the fiery body is to attract prana energy from the cosmos, prana are essential requirements of both the fiery body and material body. The karma body is like a cover of clouds that hides and restrains the natural powers of the soul. The composite subtle body can be compared to mind containing records memory, beliefs, instincts, emotions and thoughts.

The karma body is made of karma *vargana*, which are attracted from the cosmos and bound to the soul on account of attachment and aversion traits that are generally associated with physical, mental, and emotional activities. The karma body carries the impression, good or bad, typical of action performed, in the form of memory records that can last life after life for thousands of years. There is a scientific evidence to suggest that karma body may be composed of coherent electromagnetic field that emits bio photons, which are supposed to regulate chemical activity in cells. The fiery body is assigned two important functions (1) management of body functions, and (2) to support and provide

control on the physical body. Prana energy is essential to discharge these functions. The fiery body is supposed to comprise of plasma like matter. Both the non-physical soul and physical mind are co-extensive with the material body.

There are scientific observations that there is something like a cluster of light, which remains intact after the clinical death of body. The Soviet scientists have endorsed the philosophical doctrine of 're-birth' or the cycle of births. They assert with certainty, "There exists a subtle energy or an invisible body in the form of cluster of light, which covers the physical body in all living beings; we have obtained a proof for that."

Freud said that the unconscious mind is the storehouse of instinctual desires but he didn't clearly mention the source of these desires. The animal-like instincts in human beings indicate to his animal history when the impressions in form of karma were formed that produce the animal instincts in human beings. Thus the karma body containing long-term unconscious memory of past lives can be compared to unconscious mind, the id. The fiery body containing mental records of thoughts, beliefs, emotions and conscious memory (of this life) that perform the functions enumerated above can be compared to conscious mind, the Ego.

Jainism divides mind in two parts, physical mind and psychical mind. The physical mind is taken as the conscious mind here. The psychical mind is the soul's capacity to perform mental functions like thinking, feeling, willing, etc. and the physical mind contains the physical imprints of these psychical activities. The physical mind derives its power from the soul and acts on the physical plane. It is influenced by the external world, including body, and influences the soul. The mind is organ of apprehending all objects of all sense organs of the three periods of time. The physical mind interacts with the brain.

The non-physical soul is immortal and is embodied due to his karma. The soul transcends from one body to another in accordance with his karma. During migration from one material body to another the mind comprising of subtle karma body and fiery body remains united with the soul. Thus there is a continuity of mundane existence and

the past karmas determine the present life of the soul. The soul is supposed to contain innumerable parts mathematically (otherwise it is an indivisible unit) and so is the karma body. Each part of the karma body contains the total and identical memory information. In the transition from one body to another perhaps only a few parts of karma body are carried forward by the soul, the remaining parts may dissociate as *vargana* and dispersed in the cosmos. The next life beginning with the single cell starts with a miniature karma body, which then multiplies with cells. The structure of the fiery body doesn't contain parts like karma body and assuming that only a fraction of it migrates, the mind states and thought records are not carried to next life. We therefore don't consciously remember our past. The soul has a free will, but this is influenced by rising karma making our behaviour, and conduct subjective. So the soul actually has a relative free will biased by karma.

The interaction between mind and body is physical, taking place through radiations known as *adhyvasaya* and *lesya*. This interaction is both ways, that is mind and body mutually influence each other. The interaction between soul and karma body is non-physical and can be compared to parallelism. The non-physical soul undergoes continuous transformation and change in modes in a subtle way due to thoughts and actions being performed. There is a corresponding change in the karma body by the principle of reflection. This change is either in the form of new karma being bond or fruition of existing karma. There is always an exact correspondence between the state of the soul and the state of the karma body; a change in one causes a corresponding and equal change in the other. The fruition of karma produces radiations, which influence the conscious mind and also the chemical and electrical activity in the body. The DNA in every cell is identical but each cell performs differently, this kind of selective function of DNA can be assigned to karma. There is laboratory evidence that DNA is influenced and reprogrammed by radio and light frequencies. It must be karma radiations, which regulate the non-protein making part of genes through a process of selection, and determine different functions of cells suitable to their location in the body. In this manner the performance of the physical body at the cell level is regulated by the soul through karma.

Some more details of interaction between soul and karma matter is in order here. Jain philosophy provides a detailed description of this process. Distinction is made between the implications of the two terms attribute and power of the soul. An attribute is an ever-present constituent of a soul and implies a plurality of powers. The variation in the potentiality of a substance is termed as powers of the substance. When actualized these very powers give birth to the various modes. Rajamalla says: "Both soul and matter possess a power of negativity (*vibhava-sakti*) which affects bondage between the two." The negativity of the soul has been assigned the status of power, and not that of an attribute. Further, "the manifestations of the negativity of the soul appear only when the soul is in union with the karmas. In the absence of karmas the negativity manifestations are suspended, the power of negativity of the soul then yields natural positive manifestations." A distortion is described as "the perversion of a natural power of the soul." When the function of the soul with respect to an attribute is distorted by its conjunction with the karma, we get the negative manifestation, but when such a function is not obstructed, the soul yields positive manifestations.

The soul is said to possess the susceptibility of being affected by the karmas and the karma, in their turn, have the capacity of so modifying themselves that they become instruments in the process psychic manifestations. The negativity possessed by the soul and matter both makes the two liable for mutual influence. The matter having obtained the conscious manifestations of the soul merely as an auxiliary cause transforms into karma by itself. The karma becomes simply auxiliary cause of the conscious manifestations of the soul undergoing transformation by itself. Interaction and parallelism embody simply the side views of the facts of relation between the soul and matter. By holding the transcendental point of view the Jain holds that the two series of the spiritual and material manifestations run parallel and are not mutually determined.

The main property of the soul that distinguishes it from matter is *cetana*; *cetana* is not just consciousness as is generally known to philosophers but much more than that. Philosophers hold that consciousness is "awareness" or "experience" in the conscious

state, it is supposed to be absent in unconscious or in coma state. *Cetana* being property of the soul is always present, it manifests explicitly in the conscious state and implicitly in the unconscious or coma state. Without *cetana* no life is possible. The manifestation of *cetana* takes place in various ways; the principal ways being knowledge, conation, bliss (pleasure and pain), and will power. Jain philosophy assigns infinite capabilities to soul, which are fully realized when all the karma are destroyed by special efforts through activities like austerity, penance, meditation etc. There are eight main types of karma, which are grouped in two classes, psychical (*ghatin*) karma and physiological (*aghatin*) karma. Psychical karmas obstruct and limit the natural powers of the soul, viz. knowledge, conation, bliss, and will power and determine its conduct and behavioral performance in the mundane state. The physiological karma that embodies the non-physical soul can be compared to the subconscious mind, which is supposed to concern with the autonomic functions and also the physiological activities like growth, development, structure, and maintenance of the body. Table 5.1 gives some more details of the way karmas affect our personality and structure. In the normal case the soul makes contact with the object through psychical karma (and physical sense organs), which impose limits on its powers. A state known as omniscience can be attained when an individual is able to annihilate the psychical karma. In such a state the individual experiences the (super) natural powers of the soul having infinite knowledge, conation, bliss and will power. In this state the sensory organs and mental states are bypassed and the soul makes direct contact with the object, knowing and perceiving the nature in its full reality. Only the sub conscious part of unconscious mind remains in existence in the omniscient state. The soul being non-physical the limitations of space and time also vanish and the entire cosmos, living and non-living, past, present, and future, is reflected in the soul in the omniscient state.

Table 5.1 Effects of Karma

Karma imparts materialistic properties to non-physical soul as follows:

A. Psychical Karmas

1. Generate attachment and aversion qualities like anger, ego, illusion and greed.
2. Generate desires and needs like hunger, sleep, defense (fear), and mating (sex).
3. Determine the level of intelligence, knowledge, wisdom, intuition, will power, determination.
4. Determine faith, philosophical and spiritual qualities.
5. Determine personal and social conduct and behaviour.

B. Physiological Karmas

1. Construction of species-specific body,
2. Decide structural qualities of the body,
3. Determine the shape, size, proportions, appearance and other similar features of the body including deficiencies, abnormalities and disabilities.
4. Determine voice, colour, odour, skin texture and other such features of the body.
5. Regulate autonomic and physiological functions in the body.
6. Partial causes of disorders and malfunctioning of body systems and parts.
7. Fix limiting age of the body (chronological age is also determined by other factors).

We now consider the question what is knowledge? Knowledge is the property of the soul and it doesn't belong to the object. The soul possesses infinite knowledge but this is limited by "knowledge obscuring karma". It means that the "knowledge obscuring karmas" don't allow the knowledge faculty of the soul to manifest itself fully in the mind and brain. Reduction in knowledge obscuring karma, by means of methods cited above, results in increased explicit knowledge of an individual. The knowledge in the presence of knowledge obscuring karma is relative (to karma) and an individual is not able to perceive the object in all its reality. This is the reason the principles, theories and explanations advanced by imperfect individuals, possessing knowledge obscuring karma, are vulnerable to change. A perfect person, an omniscient, free of knowledge obscuring

karma, knows the object in its absolute reality and is able to describe the nature as it exists.

The knowledge in the common sense view refers to the information or empirical knowledge of the object acquired by the soul on account of its knowledge ability. The object is the auxiliary cause of knowledge, as it stimulates the soul to collect the information; the main cause is the soul himself. The information data is stored in the brain and is operated upon by the mind, both conscious and unconscious. The difference in knowledge obscuring karma is the reason for difference in intelligence by birth in individuals. The intuition is also a property of the soul and exists in varying measure in all individuals.

We can explain the interactions between the soul, mind and body with simple model. Figure-1 shows the interactions in humans and higher organisms having five senses. The karma body is shown to consisting of two parts: psychical karma and physiological karma, and the fiery body also contains two parts: the conscious mind and prana body. The karma body, conscious mind and prana or vital body are made of

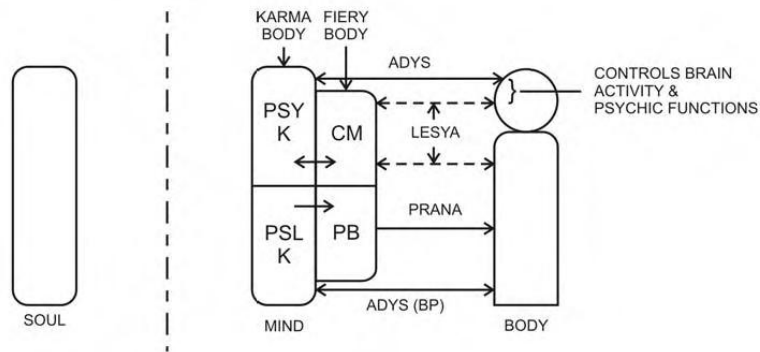

Figure 1. Interaction system in humans and higher organisms.
 PSY-K: Psychical karma; PB: Prana body; PSL-K: Physiological karma;
 ADYS: Adhyvasaya; CM: Conscious mind (physical); BP: Bio photons.

different kinds of subtle matter known as karma *vargana*, *manovargana* and *tejas vargana* respectively. The karma body reflects the changes taking place in the soul due to mental, physical and verbal activities and emits radiations known as *adhyvasaya* continuously. These *adhyvasaya* emissions interact with the conscious mind as well as

the material body, interaction with conscious mind produces another class of emissions called *lesya*. The *adhyvasaya* originating from psychical karma and *lesya* radiations interact with the brain and are supposed to control the neural activities. The *adhyvasaya* emissions originating from the physiological karma (bio-photons) interact with cells and regulate the autonomic functions and physiological activities. The *lesya* emissions from the conscious mind interact with endocrine glands and regulate their secretions and our emotions. The vital energy (*prana, tejas vargana*) drawn in from cosmos by vital body provides subtle energy to the material body without which the material body cannot function.

The soul perceives and knows the external world through senses or mind; it doesn't make direct contact with objects. This is the reason the soul is not aware of the reality, as it exists in true sense. Illusioned by external world the soul also doesn't realize the self and its powers. The perceptions made by the soul are also influenced by conscious mind. The conscious mind is a complex system working on various inputs, three main types generating the mental states or thoughts are : (a) active karma, only the rising karma are active and the rest are dormant, (b) stimuli coming from physical senses through the brain and (c) higher mental states generated by the conscious mind itself from the previous mental states. The last component is a specialty of humans who have a developed power of thinking and reasoning. One or more types of input components may act at a time to determine the total mental state. The way the three components and their combinations act decides the role of conscious mind in determining the conduct and behavior of the being, the study of which is the subject of psychology. In exceptional cases under the condition of deep meditation the conscious mind can be silenced and the soul can make contact with the unconscious mind as a result of which some karma can be dislodged and revelations like past history of the being, etc. may take place. Meditation is the principal means of spiritual progress that is accompanied by annihilation of karma.

The interactions take place both ways that is the mind and body mutually influenced each other. Fruition of karma activates the conscious mind and results in body action, and on the other hand the actions of the body, speech and conscious mind cause

bonding of karma. A balance between the state of the soul and the state of the karma body is always maintained by the principle of parallelism.

The interaction system in lower organisms having one to four senses as shown in figure 2 is simpler than that for higher organisms. These organisms don't have conscious mind and the fiery body consists of vital body only. Lower organisms also don't have a brain, the brain functions are performed by neuron network or ganglia, which are controlled by *adhyavasaya* emissions. The *adhyavasaya* emissions also control the autonomic functions and physiological activities as in higher organisms. Lower organisms don't have explicit emotions but have instincts to direct their activities. The instincts are driven by *adhyavasaya* produced by fruition of psychical karma, and the actions performed can cause bondage of karma.

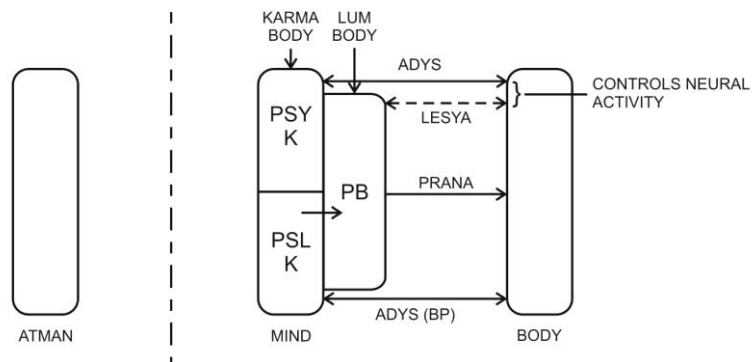

Figure 2 Interaction System in Lower Organisms

The probable interaction system in an omniscient is shown in figure-3. Humans reach the omniscient state when all the psychical karmas have been destroyed by meditation and other spiritual means. The karma body now consists of physiological karma only. In the absence of psychical karma the soul perceives the object directly and is able to perceive the reality in its true and absolute form. The whole external world (including the material body) is reflected in the soul. The perceiving soul experiences subtle changes, which are reflected in the conscious mind by the principle of parallelism, that is an impression of the perception is formed in the conscious mind. The impression

lasts for a while and assists the speech activity. The *adhyavasaya* (or *lesya*) emitted by conscious mind are pure (uncontaminated) and the expressions of the omniscient are

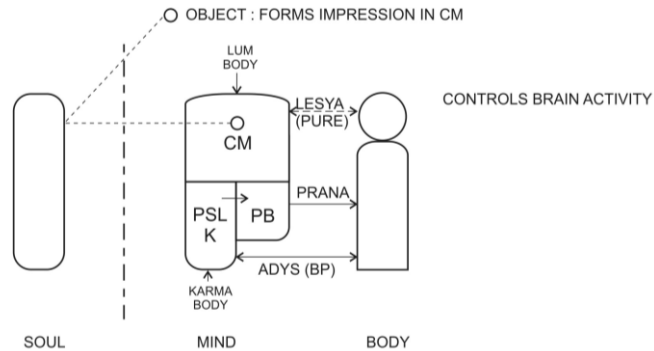

FIG. 3 : PROBABLE INTERACTION SYSTEM IN OMNISCIENT

nothing but truth, revealing the true states of the self and the nature. All the powers of the soul are expressed in an omniscient that enjoys infinite knowledge, conation, bliss and will power. In the liberated state the soul perceives but cannot express and act and there are no physical interactions in the absence of a body.

The brain is the center for information data storage and processing. The information data in the brain is received either from the senses or from the mind. All information in the conscious mind is presumably copied in the brain and is available for processing. Whether the information from the unconscious mind is also copied, and if so then in part or whole, is not known with certainty. But it is assumed that whatever information is to be processed must be available in the brain because the mind can only store and not process the information. The information processing in the brain is done at the instance of mind, which communicates with the brain through *lesya* or *adhyavasaya*. The processed information has two end uses, one for the functions of the material body and the other for the mind. We thus have four broad cases of information flow:

1. Input information received from senses and physiological activities and output information used for material body,
2. Input information received from senses and physiological activities and output information sent to mind.

3. Input information received from mind and output information used for material body.
4. Input information received from mind and the output information is also used by mind.

The first case is the major application of brain. In the second case processing of sensual and physiological inputs generates records of thoughts, emotions, desires and feelings in the conscious mind and also results in bondage of karma in the unconscious mind. In the third case the thoughts and emotions records in the conscious mind are processed in the brain and signal are sent to various parts of the body for action, no external input is required for this. In the fourth case the mind generates information by itself, thoughts from conscious mind are processed in the brain and the output appears as higher thoughts or mental states in the conscious mind; it can also result in bonding of karma in the unconscious mind. More than one type of processing can take place at a time. For example, the inputs from senses may cause activity in the body as well as generate new mental (soul) states and records in the conscious mind, or in a dream situation the inputs from the conscious mind may cause body activity in the form of rapid eye movement and generate new mental (soul) states in the form of feelings and emotions.

It is seen that brain is an important component in the working of the life system; neither mind nor body can perform without the brain. In case of head trauma or brain damage a part or whole of the information data in the brain is lost and the information processing activity is hampered, rendering the system incapable of proper functioning. But in this case also full information is still available in the mind and if the brain is restored to its initial or healthy state the information from conscious mind is again transferred to the brain and the brain resumes its normal functioning. It must be emphasized that the brain activity is not independent as is believed by materialists; it is regulated by mind, which in turn is coupled to the soul by the principle of parallelism. The soul is the source of consciousness and intelligence, which acts through mind on the

brain and body. A definite correlation between mental activity and neural activity exists and this should not be construed to mean that brain possesses consciousness or intelligence.

Rupert Sheldrake is one of the few contemporary scientists who maintain that it is possible for memory to exist without the support of the brain. David Bohm concurs with him on this possibility. Sheldrake argues that just because we don't know of any memory without the brain, it doesn't follow that there cannot be any memory outside the brain. For all we know, the brain can act as a conduit through which memory (or consciousness) manifests itself, much like the antenna and the wiring in a radio act as conduits for the electromagnetic waves to be manifested as sound. Thus, just as the radio signal can exist (in the form of electromagnetic waves) outside the radio with its antennas and wiring, memory can exist outside the brain. Sheldrake thinks that his "hypothesis of formative causation, the morphogenetic theory, is testable. This argument supports the concept proposed above that memory exists outside the brain in the conscious (and also unconscious) mind. The brain consisting of hardware is the processing center.

The conscious experience identified by "what it is like" sense is made by the soul and not the mind. The mind is physical entity and is devoid of conscious property. The phenomenal property is also possessed by the soul. The term 'conscious' in conscious mind denotes the property of the mind through which soul makes conscious experiences, the mind itself is not conscious. The *cetana* manifests in mind and body and so the mind and body are able to function in the given manner. No function of mind and body is possible without *cetana*; a 'dead' body has all the necessary organs and parts in place but cannot perform any action typical of life because the soul (*cetana*) has left the body. The dualists assign consciousness to mind and materialists to brain because mind and brain function the way they do in the presence of *cetana*. It is clear that consciousness is not the property of mind or brain. The conduct and behavior of any being is determined by his karma and *cetana* property of the soul. Jain dualism thus presents a theory of body, mind,

and spirit where the non-physical soul manifests in the body and mind and the life is explained.

We now review the objections raised against dualism. The process of fetal development was referred to above. The soul along with subtle mind enters the newly fertilized ova and modifies the DNA in accordance with its karma (through radiations). This process of entry cannot be empirically known to science as the soul is non-physical and the mind is composed of mass less subtle matter. Further growth and development of fetus takes place according to the modified DNA. According to Jain philosophy life in the form of sub microorganisms is always present even during the period of early earth. This organism must have provided the cell from which further development of life took place on earth. In Jain dualism the interaction between mind and body is through radiations and the principle of energy conservation is not violated. The soul doesn't directly interact with mind and body; its interaction with karma body is based on principle of parallelism involving no energy transfer.

A correlation between the activities of mind and brain is a requirement of the system. The brain is the apparatus providing a physical structure for the activity of mind. The neuron firings and other neuro-physiological activity in the brain are synchronized with the mental activity in the mind. Thus a correlation between mind events and neural events makes it possible to transform the mind states into physical actions. This is possible only when the brain is properly developed and is functioning. In the early period of fetus or in a trauma state a suitable brain structure is not available and the physical actions do not become possible. It shall be wrong to assign mental capabilities to neural events, as the materialists do; the driving force behind the neural activity is the mind which actualizes the powers of the soul, the ultimate source of all activity, conscious and autonomic, in the body. The objections of Hume and Kant that the mind and soul are not apprehended due to human cognitive limitations are subjective; a person having strong karma is not in a position to do so. But an omniscient, or a person having small amount of

psychical karma, can apprehend mind and soul. He has the direct first-person experience of the reality in its absolute form.

Conclusions

Dualism and materialism the two broad traditional metaphysical views concerning soul or mind suffer from some objections. Jain dualism, a special kind of dualism consisting of three units of non-physical soul, subtle mind and material body, avoids these objections. According to Jain philosophy the subtle mind consists of karma body, unconscious mind, and fiery body, the conscious mind. The karma imparts physical properties to the non-physical soul and the fiery body contains records of thoughts, beliefs, emotions and short-term memory. The non-physical soul is immortal but undergoes cycles of birth and death due to effects of karma. Consciousness and intelligence are properties of the soul and not of mind or brain. Consciousness exists in all organisms at all times and in all conditions whether awake or in coma. The brain is the center for storage and processing of information data, it processes information for the requirements of the body as well as the mind. The mind events and brain events are correlated to ensure a perfect harmony in the system and that all components of the system work as faithful units to uphold the sovereign existence of the mundane soul.

Bibliography:

1. Dualism and Mind, Internet Encyclopedia of Philosophy.
2. www.icp.utm.edu/c/conscious.htm
3. Knowledge Argument Against Physicalism, Internet Encyclopedia of Philosophy
4. Unconscious Mind-Wikipedia, the free encyclopedia.
5. DNA, Design and the origin of life.
6. N.L. Kachhara, Jaina Doctrine of Karma, 2005.
7. N.L. Kachhara, "Satdravya ki Vaigyanik Mimamsa" Prakrit Bharati Academy, Jaipur, 2007.

8. Dr. S.C. Jain, "Structures and Functions of Soul in Jainism", Bharatiya Gyanpeeth, 2006.
9. Acharya Mahaprajna, "Philosophical Foundations of Jainism" Adarsh Sahitya Sangh, New Delhi, 2002.
10. Psyche.htm
11. Rupert Sheldrake, "What Survives?" in Doore, Gary (ed.), Tarcher, Los Angeles, 1990.